

Click-Less™ True-Bypass BOSS TU-2 Chromatic Tuner Install Guide

©2010 Jack Deville Electronics LLC, all rights reserved



ABOUT THIS MANUAL

This manual covers Click-Less™ True-Bypass installation for the BOSS TU-2 Chromatic Tuner.

It is recommended that you read this manual in full and become familiar with the installation procedure before beginning any work.



RECOMMENDED TOOL AND SUPPLY LIST:

- Click-Less™ True-Bypass installation kit
- Soldering station (with temperature control/regulation)
- Solder & Flux
- De-soldering braid or solder sucker
- Wire strippers
- Wire cutters
- Phillips head screwdriver
- Double-stick foam tape

OVERVIEW

The BOSS TU-2 employs buffered electronic switching and electronic signal routing comprised of four main circuit elements:

- A buffer/driver circuit used to prevent loading of the signal path and to drive the electronic switching circuit
- Two FETs (field effect transistors) used to block/permit signal flow through the bypass and effect circuits
- A flip-flop circuit used to select which FET is ON/OFF (BYPASS/EFFECT) and route the signal appropriately
- A mechanical momentary contact switch used to control the flip-flop circuit and engage the tuner circuit

Installing Click-Less™ True-Bypass requires circumvention of the electronic switching system and re-routing the signal path through the Click-Less™ PCB.

Step 1:

Remove the backing plate and flip the effect PCB upright as shown below:

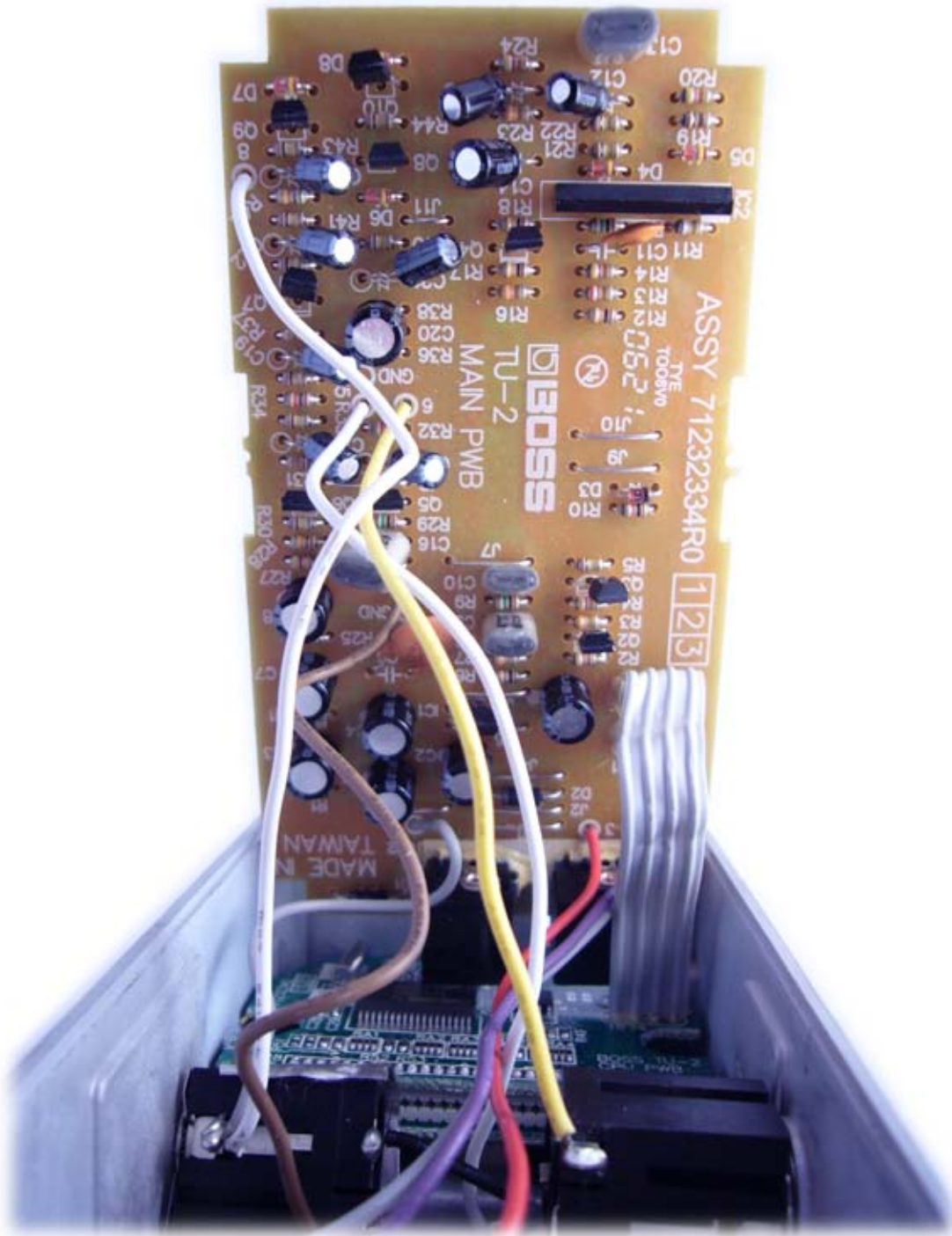

Step 2:

Locate , de-solder and remove R2 (47K resistor) from the effect PCB:

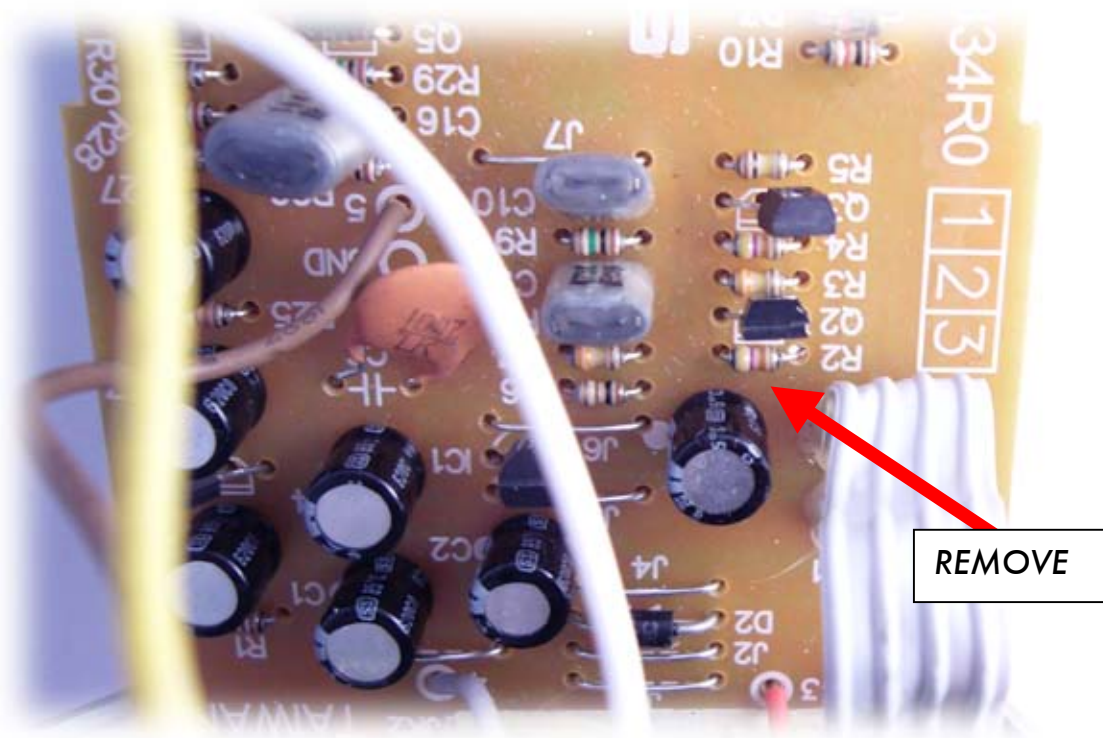

Step 3A:

Locate, de-solder and remove the input wire from Hole 5 shown below:

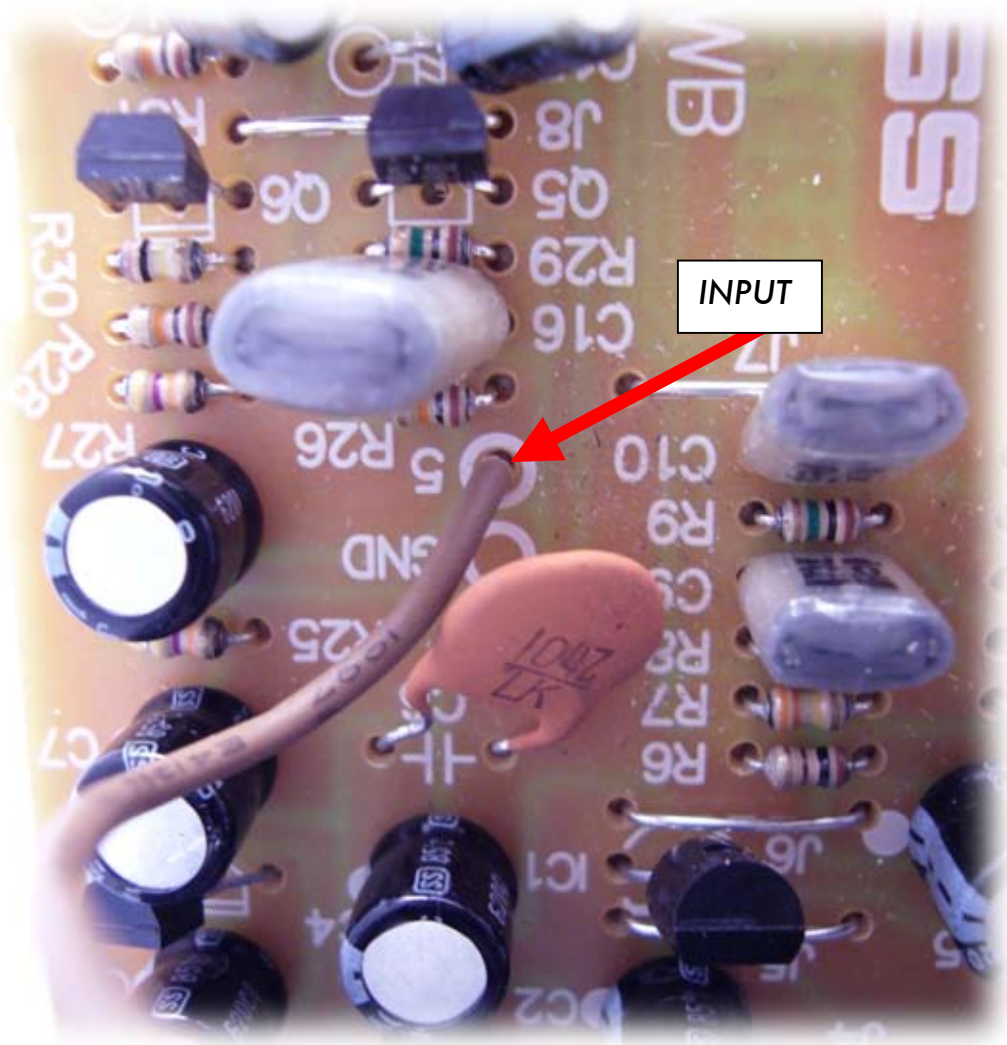

Step 3B:

Locate, de-solder and remove the output wire from Hole **7** shown below:

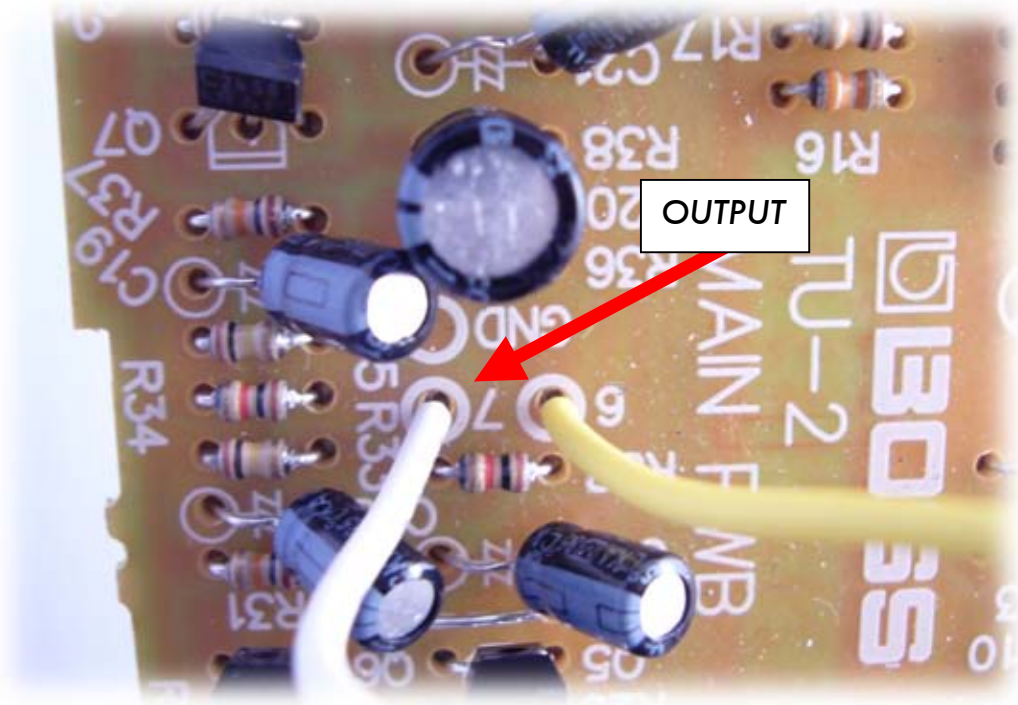

Step 3C:

Locate, de-solder and remove the switch wire from Hole 2 shown below:

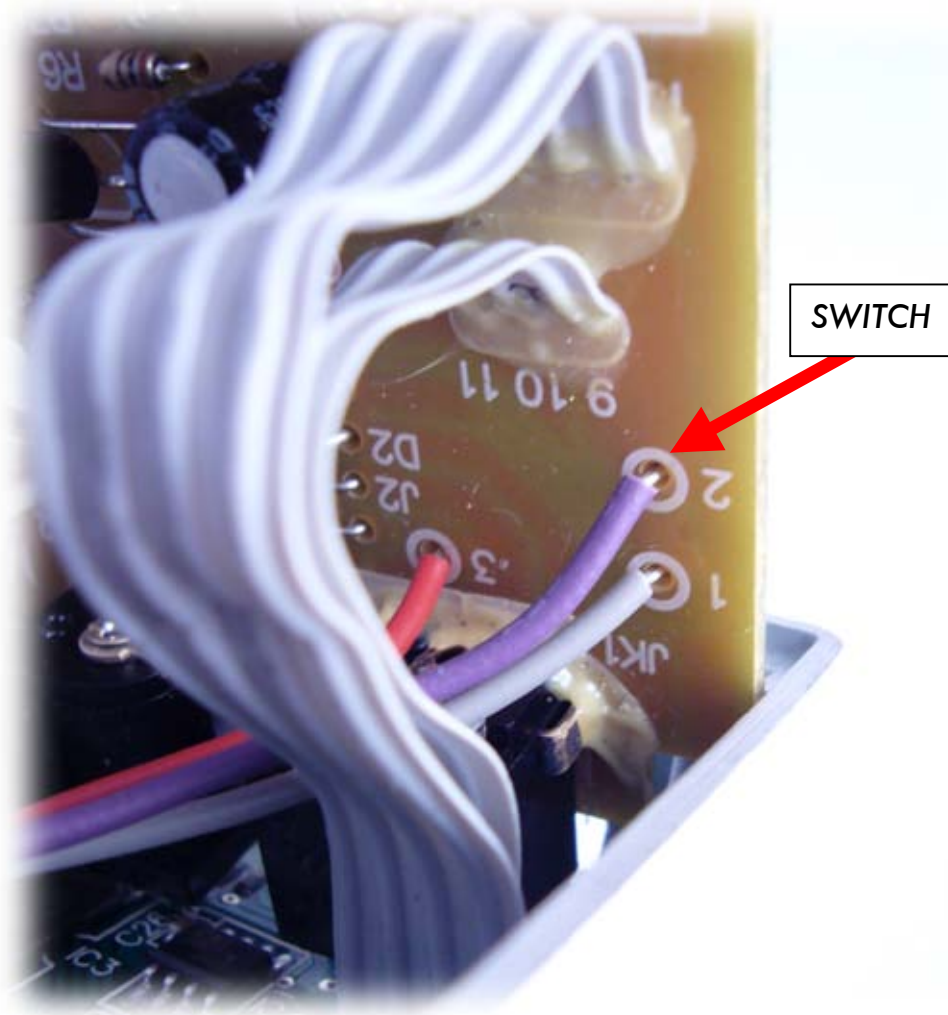

Step 4:

Solder five of the supplied wires into the Click-Less™ PCB pads following the diagram below:

NOTE: Wire color employed may vary. Colors indicated below are provided for reference only.

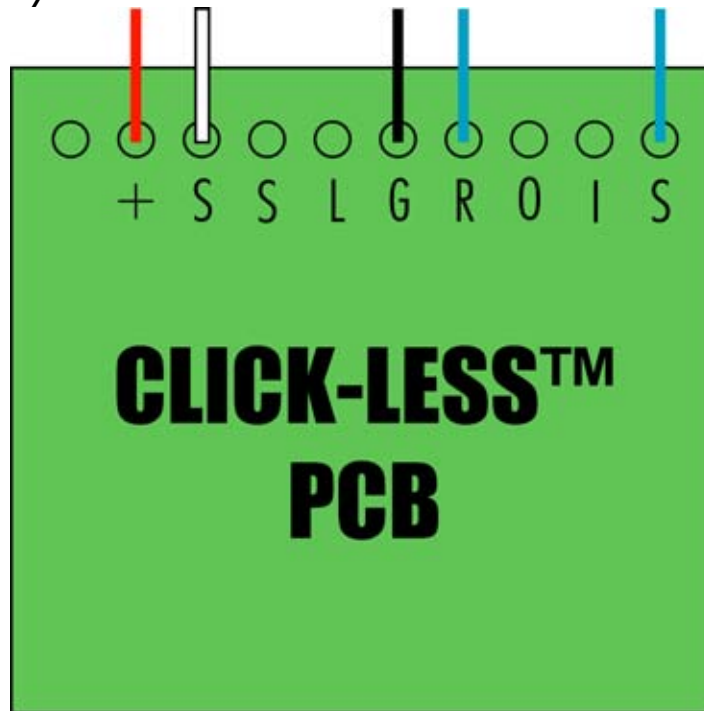

- **+** power pad. (Red wire shown)
- **S** switch pad (White wire shown)
- **G** ground pad. (Black wire shown)
- **R** return pad. (Blue wire shown)
- **S** send pad. (Blue wire shown)

Step 5A:

Connect the Click-Less™ PCB **S** Send wire to the effect PCB Hole **5**:

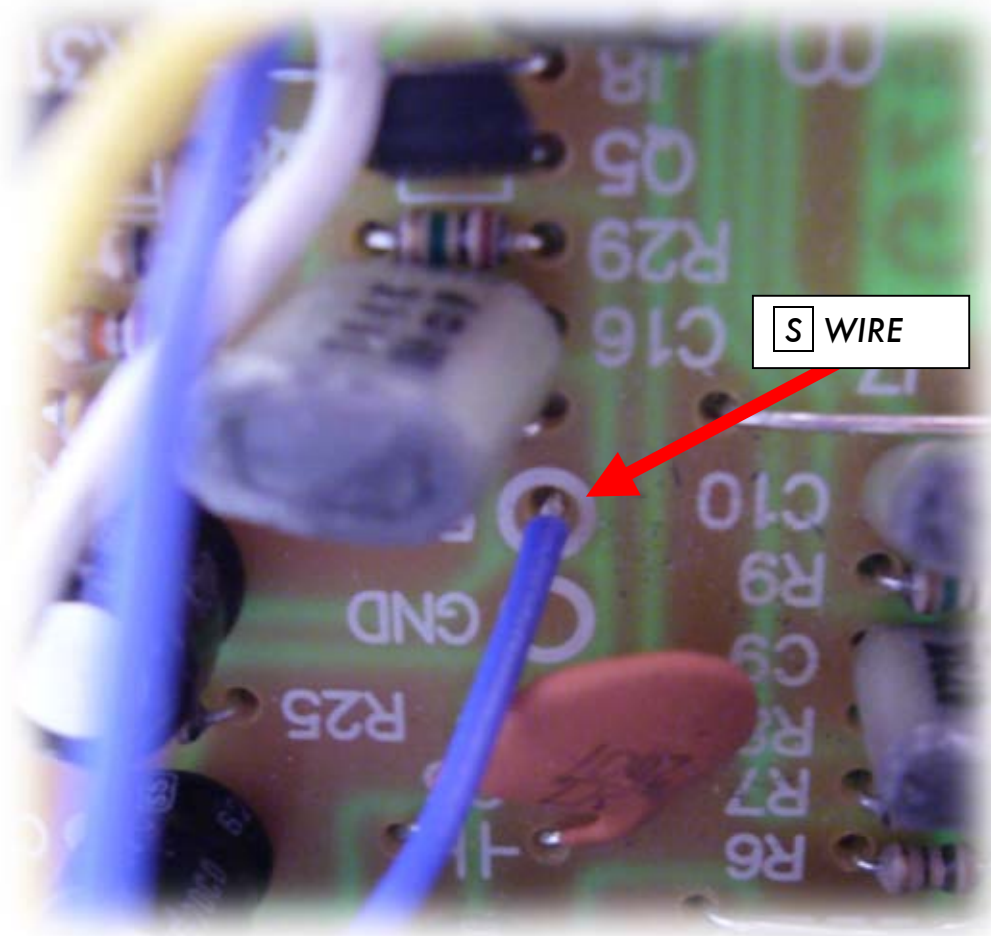

Step 5B:

Connect the Click-Less™ PCB **R** Return wire to the effect PCB Hole **7**:

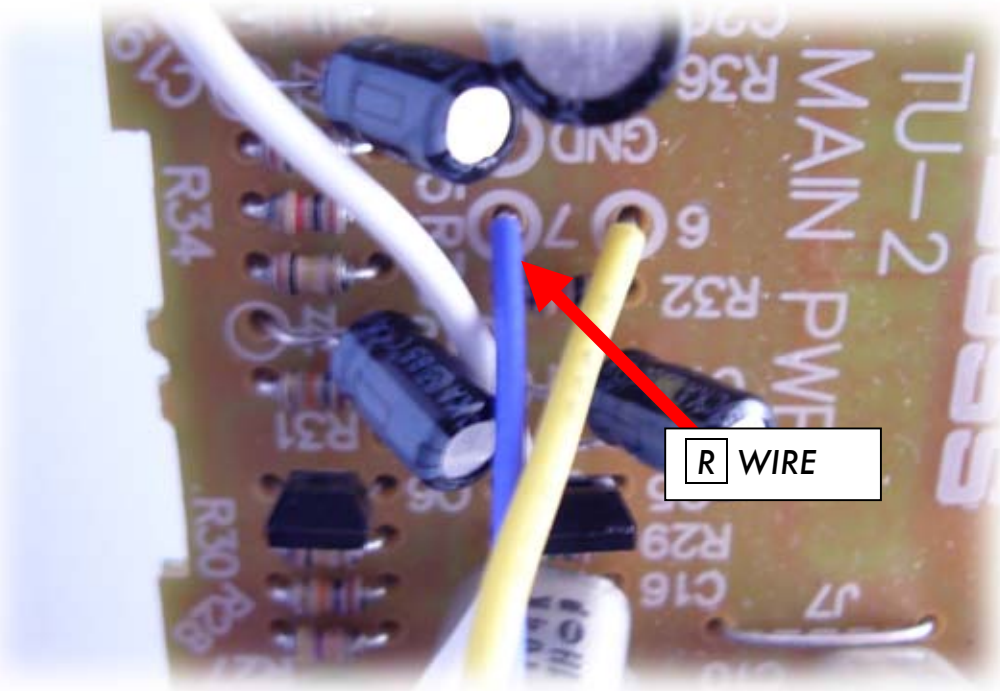

Step 5C:

Connect the Click-Less™ PCB **S** Switch wire and the original switch wire to the effect PCB Hole **2**:

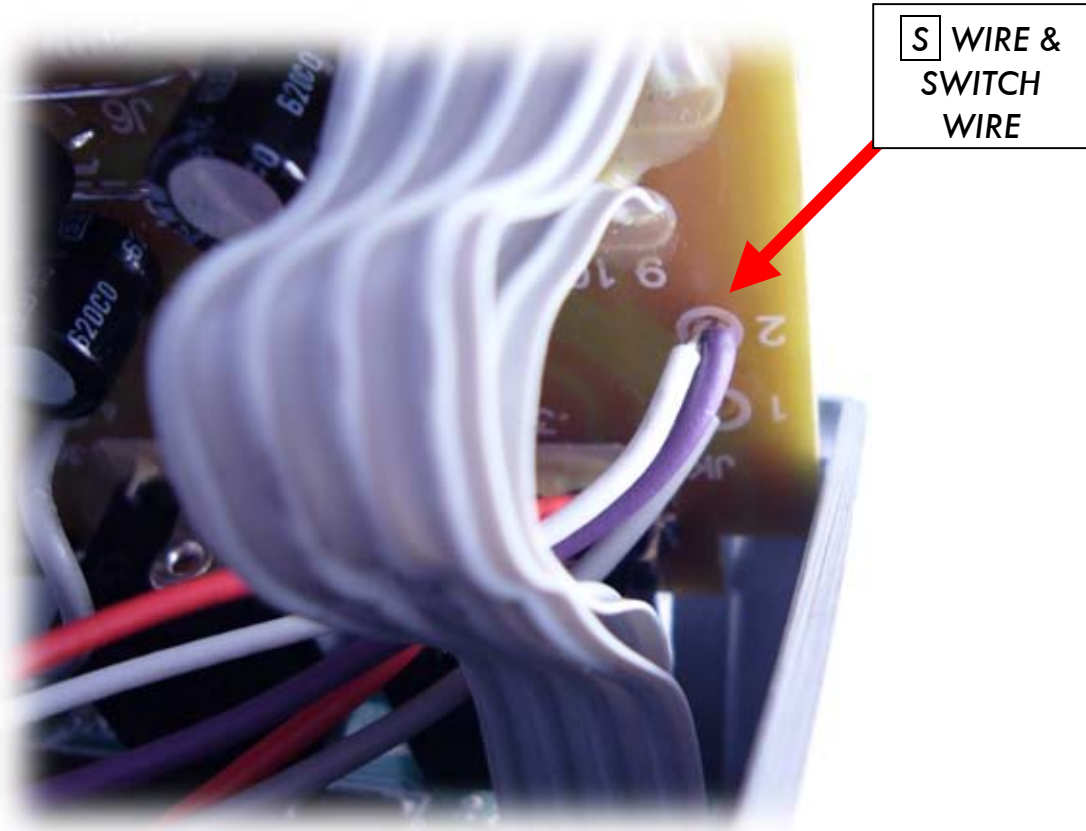

Step 5D:

Connect the Click-Less™ PCB + power wire to the reverse polarity protection diode cathode lead (cathode lead indicated by band on diode body) as shown below:

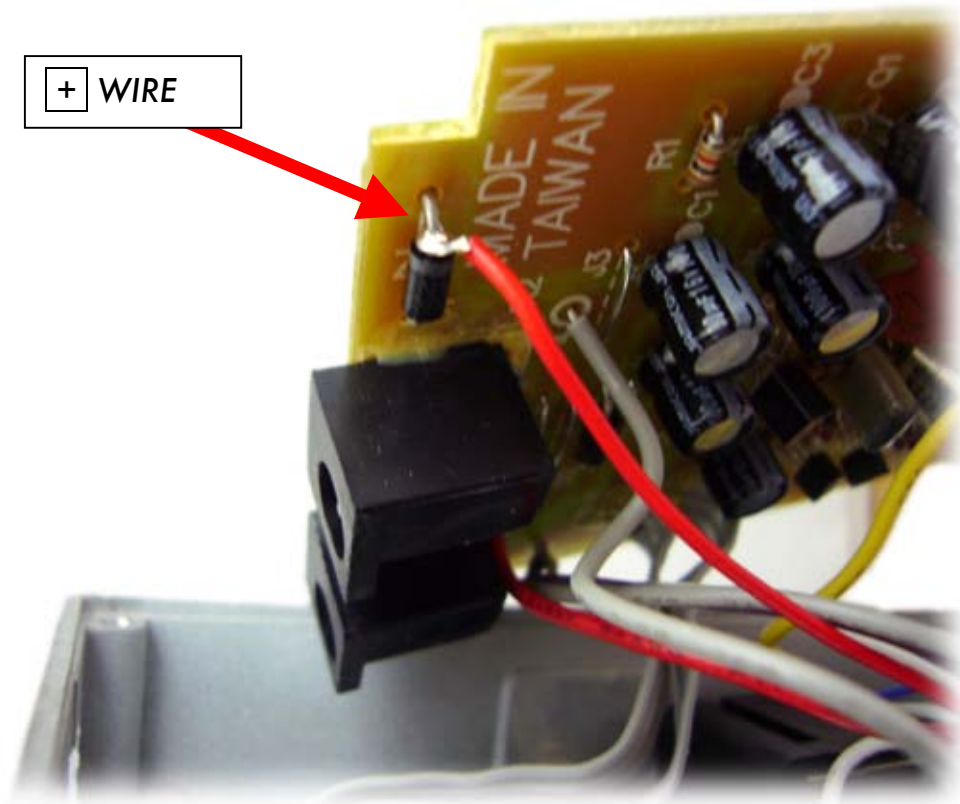

Step 6:

Solder the remaining wires to the Click-Less™ PCB pads following the diagram below:

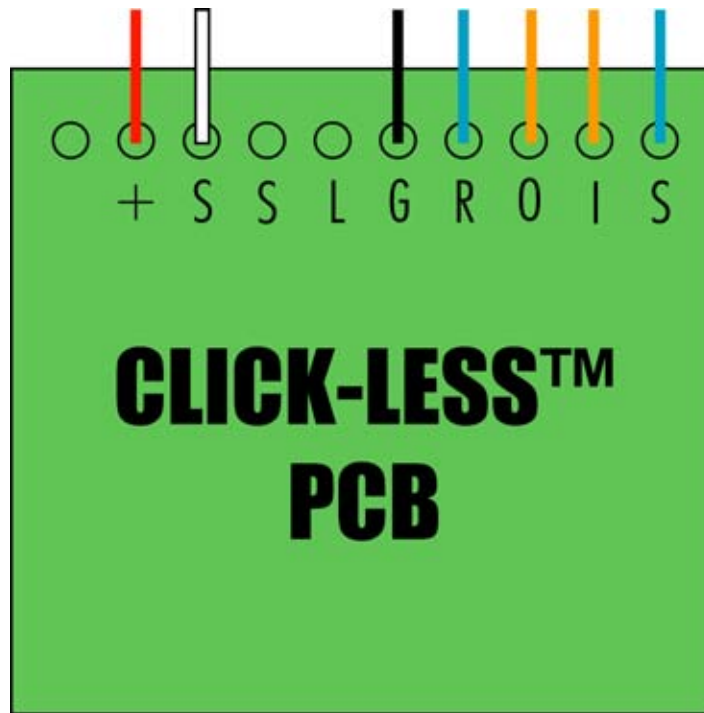

- **G** ground wire to output jack ground lug
- **O** output pad to output jack wire
- **I** input pad to input jack wire

Step 7:

Apply double stick tape to the back of the Click-Less™ PCB taking care to ensure that no leads are poking through the tape, and secure the Click-Less™ PCB inside the chassis at a suitable location. Recommended placement is on the inside of the chassis, just below the output jack. See photo below:



Congratulations! Your TU-2 Chromatic Tuner is now Click-Less™ True-Bypass.

Use the OUTPUT jack for true-bypass operation, use the BYPASS jack for buffered operation.

Note: The tuner must be ON in order for the BYPASS output to pass signal.